

MICROPROCESSOR MONITOR

FEATURES

- Precision Voltage Monitor Adjustable +4.5V or +4.75V
- Reset Pulse Width 250msec Min
- No External Components
- Adjustable Watchdog Timer 150msec, 600msec or 1.2sec
- Debounced Manual Reset Input for External Override

APPLICATIONS

- Computers
- Controllers
- Intelligent Instruments
- Automotive Systems
- Critical μ P Power Monitoring

ORDERING INFORMATION

Part No.	Package	Temp. Range
TC1232COA	8-Pin SOIC	0°C to +70°C
TC1232COE	16-Pin SOIC (Wide)	0°C to +70°C
TC1232CPA	8-Pin PDIP	0°C to +70°C
TC1232EOA	8-Pin SOIC	-40°C to +85°C
TC1232EOE	16-Pin SOIC (Wide)	-40°C to +85°C
TC1232EPA	8-Pin PDIP	-40°C to +85°C

GENERAL DESCRIPTION

The TC1232 is a fully-integrated processor supervisor. It provides three important functions to safeguard processor sanity: precision power on/off reset control, watchdog timer and external reset override.

On power-up, the TC1232 holds the processor in the reset state for a minimum of 250msec after V_{CC} is within tolerance to ensure a stable system start-up.

Microprocessor sanity is monitored by the on-board watchdog circuit. The microprocessor must provide a periodic low-going signal on the \overline{ST} input. Should the processor fail to supply this signal within the selected time-out period (150msec, 600msec or 1200msec), an out-of-control processor is indicated and the TC1232 issues a processor reset as a result.

The outputs of the TC1232 are immediately driven active when the PB input is brought low by an external push-button switch or other electronic signal. When connected to a push-button switch, the TC1232 provides contact debounce.

The TC1232 is packaged in a space-saving 8-pin plastic DIP or SOIC package and requires no external components.

FUNCTIONAL BLOCK DIAGRAM

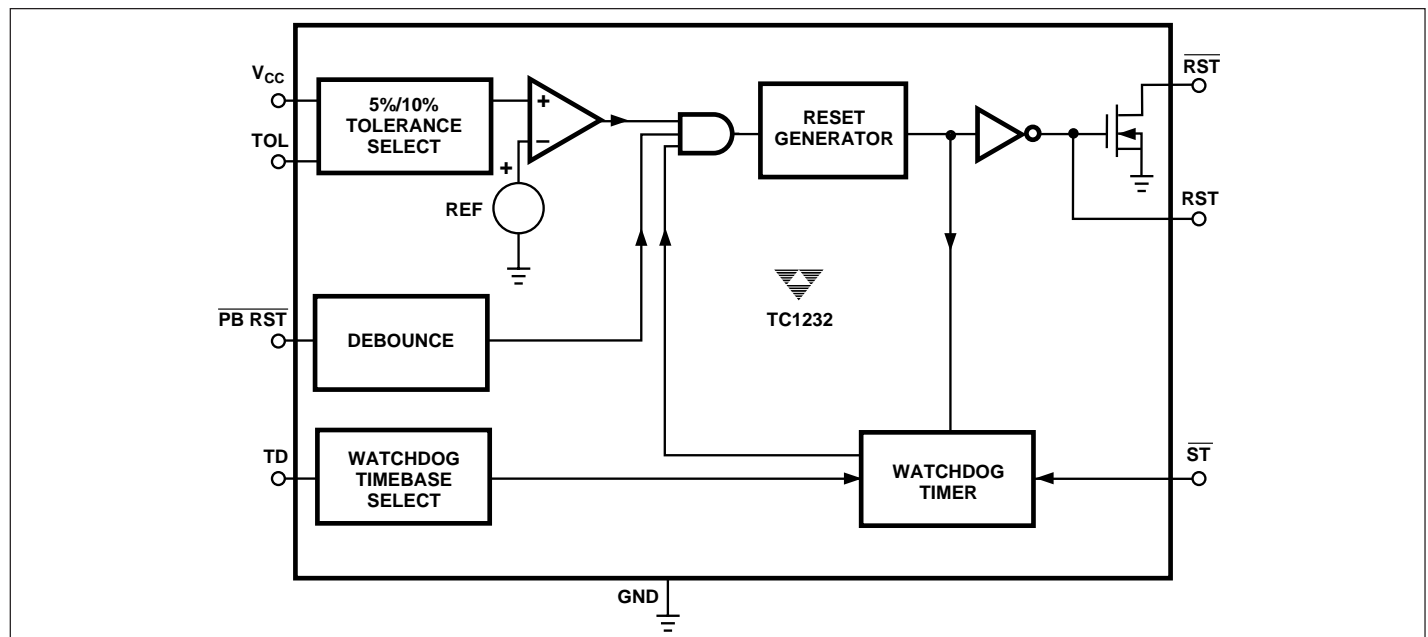

TC1232

ABSOLUTE MAXIMUM RATINGS*

Voltage on Any Pin (With Respect to GND) – 0.3V to +5.8V

Operating Temperature Range:

TC1232C 0°C to +70°C

TC1232E – 40°C to + 85°C

Storage Temperature Range – 65°C to +150°C

Lead Temperature (Soldering, 10 sec) +300°C

*Stresses beyond those listed under "Absolute Maximum Ratings" may cause permanent damage to the device. These are stress ratings only, and functional operation of the device at these or any other conditions beyond those indicated in the operational sections of the specifications is not implied. Exposure to absolute maximum rating conditions for extended periods may affect device reliability.

DC ELECTRICAL CHARACTERISTICS: $T_A = T_{MIN}$ to T_{MAX} ; $V_{CC} = +4.5V$ to $5.5V$, unless otherwise specified.

Symbol	Parameter	Test Conditions	Min	Typ	Max	Unit
V_{CC}	Supply Voltage		4.5	5.0	5.5	V
V_{IH}	\overline{ST} and $\overline{PB RST}$ Input High Level	Note 1	2.0	—	$V_{CC} + 0.3$	V
V_{IL}	\overline{ST} and $\overline{PB RST}$ Input Low Level		– 0.3	—	+0.8	V
I_L	Input Leakage \overline{ST} , TOL		– 1.0	—	+1.0	μA
I_{OH}	Output Current RST	$V_{OH} = 2.4V$	– 1.0	–12	—	mA
I_{OL}	Current RST, \overline{RST}	$V_{OL} = 0.4V$	2.0	10	—	mA
I_{CC}	Operating Current	Note 2	—	50	200	μA
V_{CCTP}	V_{CC} 5% Trip Point (Note 3)	TOL = GND	4.50	4.62	4.74	V
V_{CCTP}	V_{CC} 10% Trip Point (Note 3)	TOL = V_{CC}	4.25	4.37	4.49	V

CAPACITANCE (Note 4): $T_A = +25^\circ C$

Symbol	Parameters	Test Conditions	Min	Typ	Max	Units
C_{IN}	Input Capacitance \overline{ST} , TOL		—	—	5	pF
C_{OUT}	Output Capacitance RST, \overline{RST}		—	—	7	pF

AC ELECTRICAL CHARACTERISTICS: $T_A = T_{MIN}$ to T_{MAX} ; $V_{CC} = +5V$ to $\pm 10\%$, unless otherwise specified.

Symbol	Parameters	Test Conditions	Min	Typ	Max	Units
t_{PB}	$\overline{PB RST}$ (Note 5)	Figure 3	20	—	—	msec
t_{PBD}	$\overline{PB RST}$ Delay	Figure 3	1	4	20	msec
t_{RST}	Reset Active Time		250	610	1000	msec
t_{ST}	\overline{ST} Pulse Width	Figure 4	75	—	—	nsec
t_{TD}	\overline{ST} Time-out Period	Figure 4				
		TD Pin = 0V	62.5	150	250	msec
		TD Pin = Open	250	600	1000	msec
		TD Pin = V_{CC}	500	1200	2000	msec
t_F	V_{CC} Fall Time (Note 4)	Figure 5	10	—	—	μsec

MICROPROCESSOR MONITOR

TC1232

AC ELECTRICAL CHARACTERISTICS: (Cont.) $T_A = T_{MIN}$ to T_{MAX} ; $V_{CC} = +5V$ to $\pm 10\%$, unless otherwise specified.

Symbol	Parameter	Test Conditions	Min	Typ	Max	Units
t_R	V_{CC} Rise Time (Note 4)	Figure 6	0	—	—	μsec
t_{RPD}	V_{CC} Detect to RST High and RST Low	Figure 7, V_{CC} Falling	—	—	100	nsec
t_{RPU}	V_{CC} Detect to RST High and RST Open (Note 6)	Figure 8, V_{CC} Rising	250	610	1000	msec

- NOTES:**
1. $\overline{\text{PB RST}}$ is internally pulled up to V_{CC} with an internal impedance of typically 40k Ω .
 2. Measured with outputs open.
 3. All voltages referenced to GND.
 4. Guaranteed by design.
 5. $\overline{\text{PB RST}}$ must be held low for a minimum of 20msec to guarantee a reset.
 6. $t_R = 5\mu\text{sec}$.

PIN CONFIGURATIONS

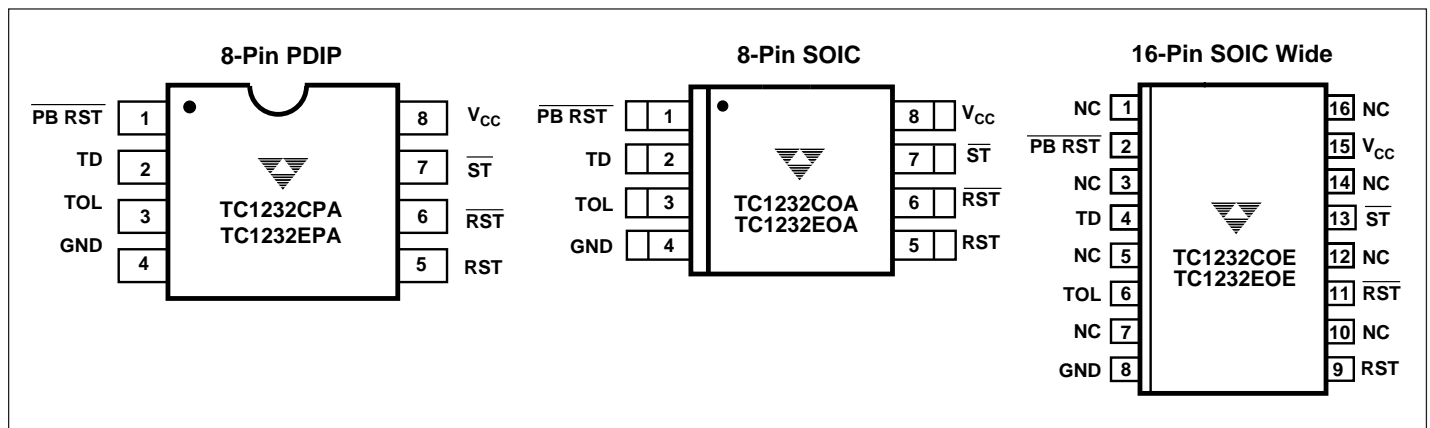

PIN DESCRIPTION

Pin No. (8-Pin PDIP)	Pin No. (8-Pin SOIC)	Pin No. (16-Pin SOIC)	Symbol	Description
1	1	2	$\overline{\text{PB RST}}$	Push-button Reset Input. A debounced active-low input that ignores pulses less than 1msec in duration and is guaranteed to recognize inputs of 20msec or greater.
2	2	4	TD	Time Delay Set. The watchdog time-out select input ($t_{TD} = 150\text{msec}$ for TD = 0V, $t_{TD} = 600\text{msec}$ for TD = open, $t_{TD} = 1.2\text{sec}$ for TD = V_{CC}).
3	3	6	TOL	Tolerance Input. Connect to GND for 5% tolerance or to V_{CC} for 10% tolerance.
4	4	8	GND	Ground.
5	5	9	RST	Reset Output (Active High) - goes active: 1. If V_{CC} falls below the selected reset voltage threshold 2. If $\overline{\text{PB RST}}$ is forced low 3. If $\overline{\text{ST}}$ is not strobed within the minimum time-out period 4. During power-up
6	6	11	$\overline{\text{RST}}$	Reset Output (Active Low, Open Drain) - see RST.
7	7	13	$\overline{\text{ST}}$	Strobe Input. Input for watchdog timer.
8	8	15	V_{CC}	The +5V Power-Supply Input.
		1, 3, 5, 7, 10, 12, 14, 16	NC	No Internal Connection.

TC1232

DETAILED DESCRIPTION

Power Monitor

The TC1232 detects out-of-tolerance power supply conditions and warns a processor-based system of an impending power failure. When V_{CC} is detected as below the preset level defined by TOL, the V_{CC} comparator outputs the signals \overline{RST} and \overline{RST} . If TOL is connected to ground, the \overline{RST} and \overline{RST} signals become active as V_{CC} falls below 4.75 volts. If TOL is connected to V_{CC} , the \overline{RST} and \overline{RST} become active as V_{CC} falls below 4.5 volts. Because the processing is stopped at the last possible moment of valid V_{CC} , the \overline{RST} and \overline{RST} are excellent control signals for a μP . The reset outputs will remain in their active states until V_{CC} has been continuously in-tolerance for a minimum of 250msec allowing the power supply and μP to stabilize before \overline{RST} is released.

Push-button Reset Input

The debounced manual reset input ($\overline{PB RST}$) manually forces the reset outputs into their active states. Once $\overline{PB RST}$ has been low for a time t_{PBD} , the push-button delay time, the reset outputs go active. The reset outputs remain in their active states for a minimum of 250msec after $\overline{PB RST}$ rises above V_{IH} (Figure 3).

A mechanical push-button or active logic signal can drive the $\overline{PB RST}$ input. The debounced input ignores input pulses less than 1msec and is guaranteed to recognize pulses of 20msec or greater. No external pull-up resistor is required because the $\overline{PB RST}$ input has an internal pull-up to V_{CC} of approximately 100 μA .

Watchdog Timer

When the \overline{ST} input is not stimulated for a preset time period, the watchdog timer function forces \overline{RST} and \overline{RST} signals to the active state. The preset time period is determined by the \overline{TD} inputs to be 150msec with TD connected to ground, 600msec with TD floating, or 1200msec with TD connected to V_{CC} , typical. The watchdog timer starts timing out from the set time period as soon as \overline{RST} and \overline{RST} are inactive. If a high-to-low transition occurs on the ST input pin prior to time-out, the watchdog timer is reset and begins to time-out again. If the watchdog timer is allowed to time-out, then the \overline{RST} and \overline{RST} signals are driven to the active state for 250msec minimum (Figure 2).

The software routine that strobes \overline{ST} is critical. The code must be in a section of software that is executed frequently enough so the time between toggles is less than the watchdog time-out period. One common technique controls the μP I/O line from two sections of the program. The software might set the I/O line high while operating in the foreground

mode and set it low while in the background or interrupt mode. If both modes do not execute correctly, the watchdog timer issues reset pulses.

Supply Monitor Noise Sensitivity

The TC1232 is optimized for fast response to negative-going changes in V_{DD} . Systems with an inordinate amount of electrical noise on V_{DD} (such as systems using relays), may require a 0.01 μF or 0.1 μF bypass capacitor to reduce detection sensitivity. This capacitor should be installed as close to the TC1232 as possible to keep the capacitor lead length short.

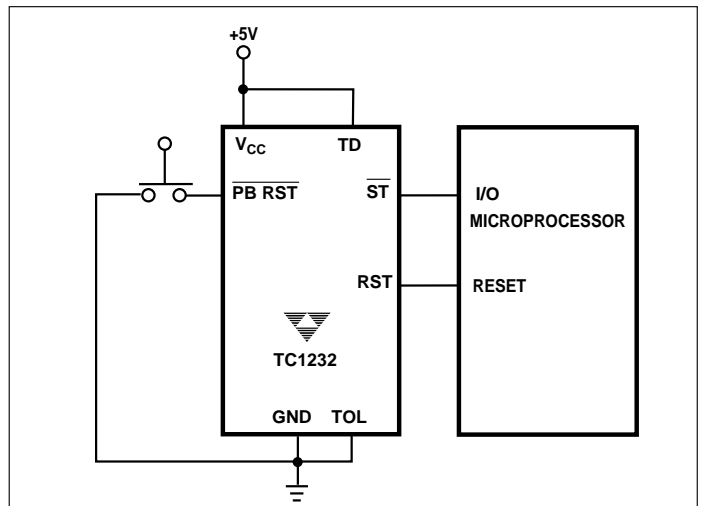

Figure 1. Push-button Reset

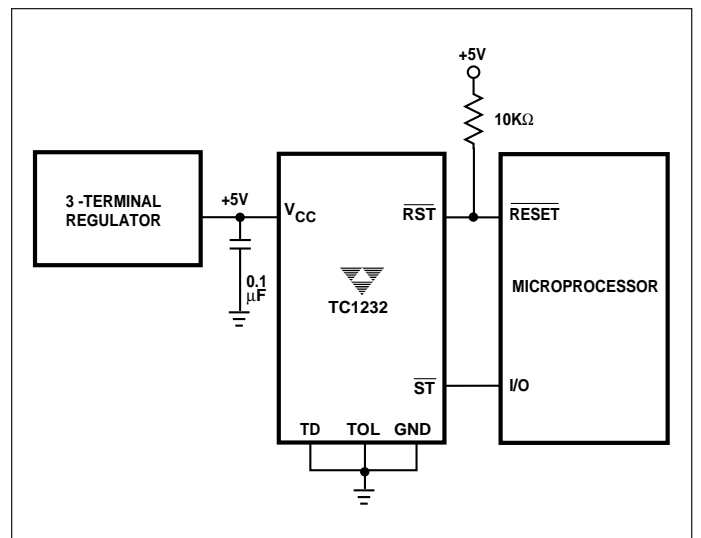

Figure 2. Watchdog Timer

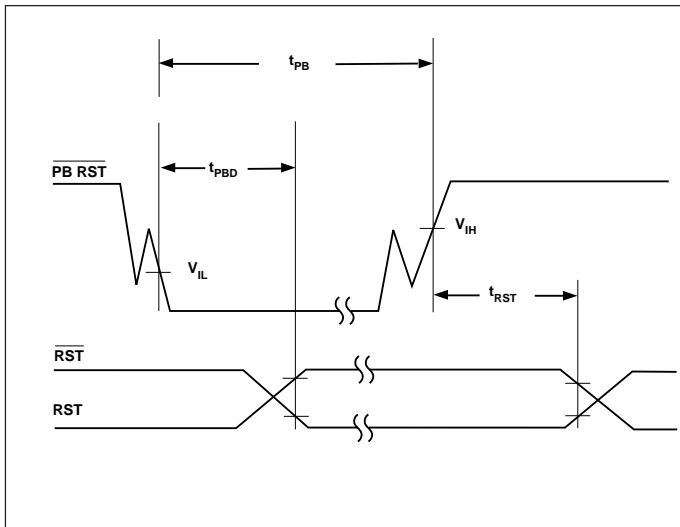

Figure 3. Push-button Reset. The debounced $\overline{\text{PB RST}}$ input ignores input pulses less than 1msec and is guaranteed to recognize pulses of 20msec or greater

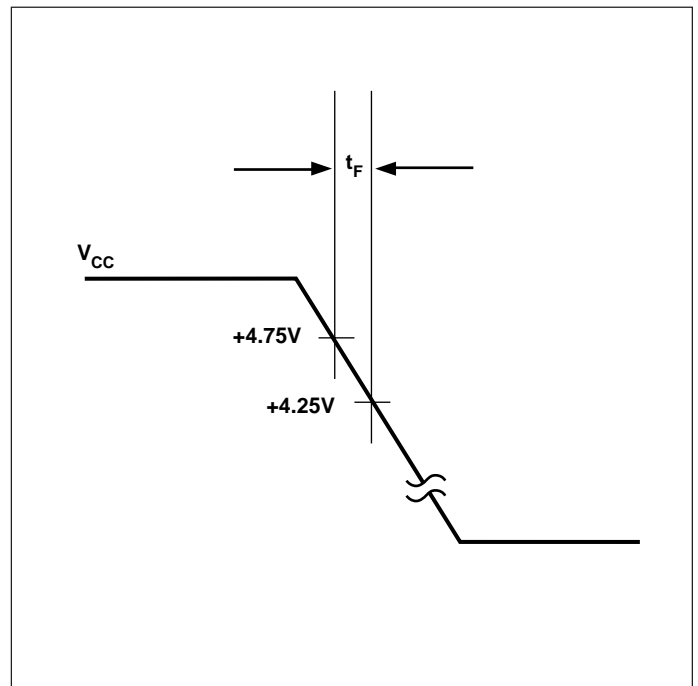

Figure 5. Power-Down Slew Rate

PUSH-BUTTON RESET

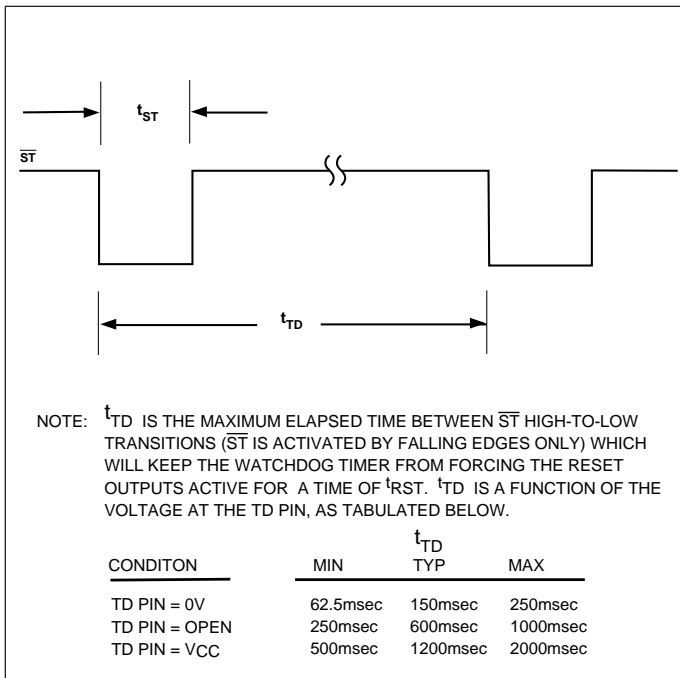

Figure 4. Strobe Input

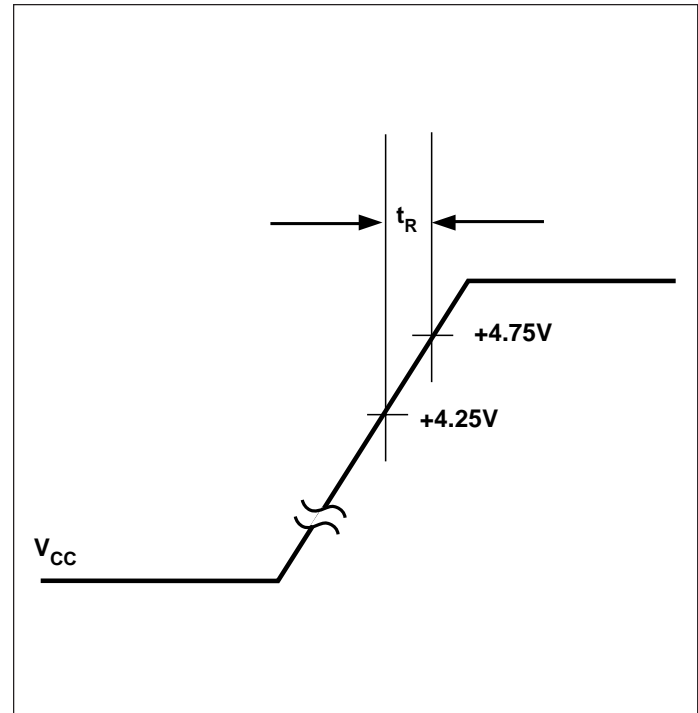

Figure 6. Power-Up Slew Rate

TC1232

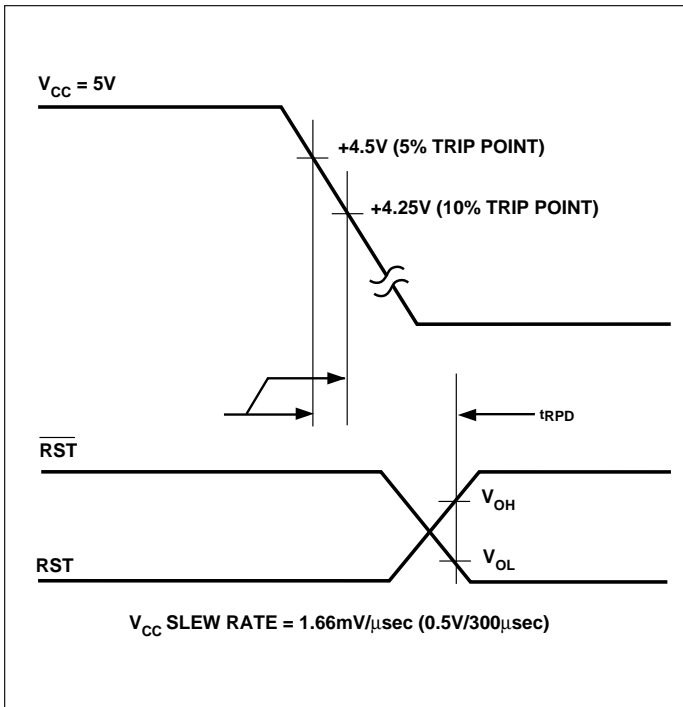

Figure 7. V_{CC} Detect Reset Output Delay (Power-Down)

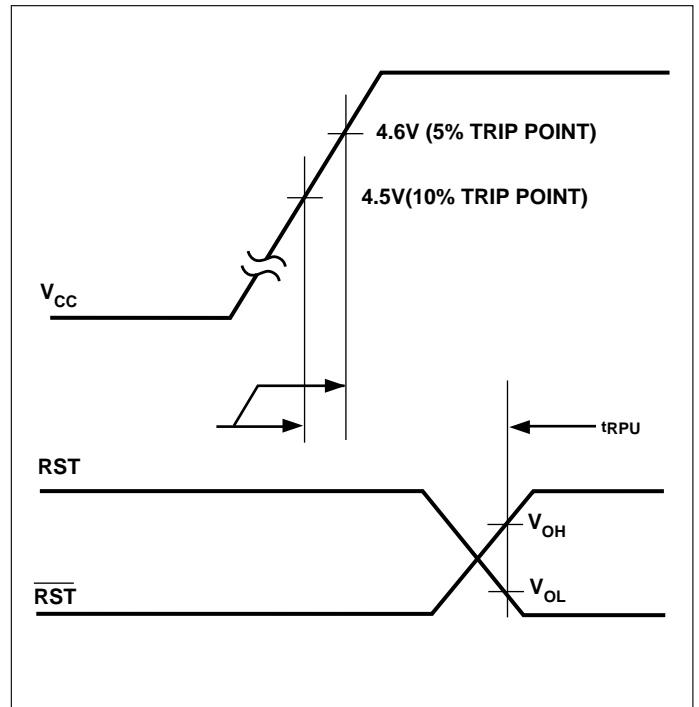
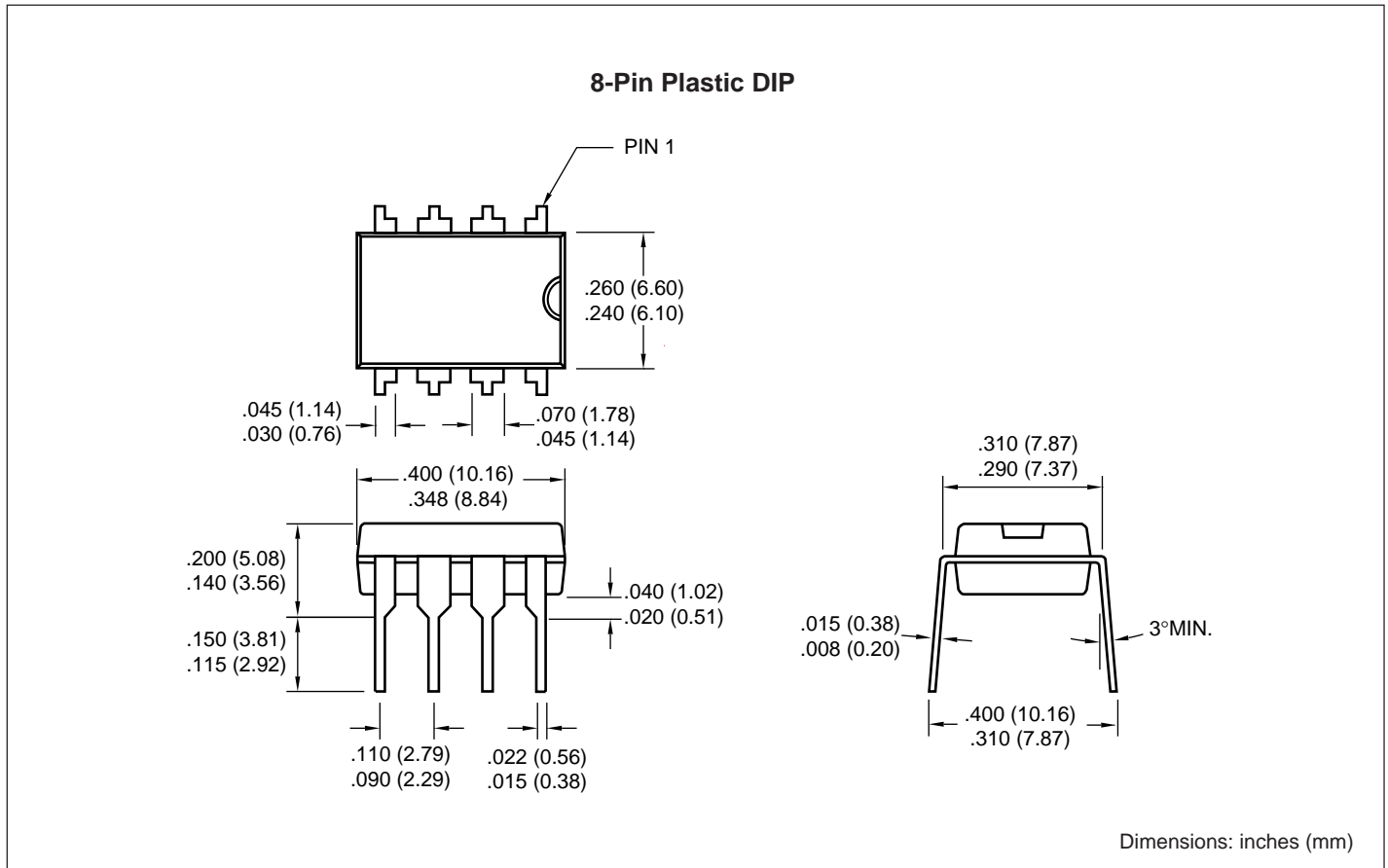
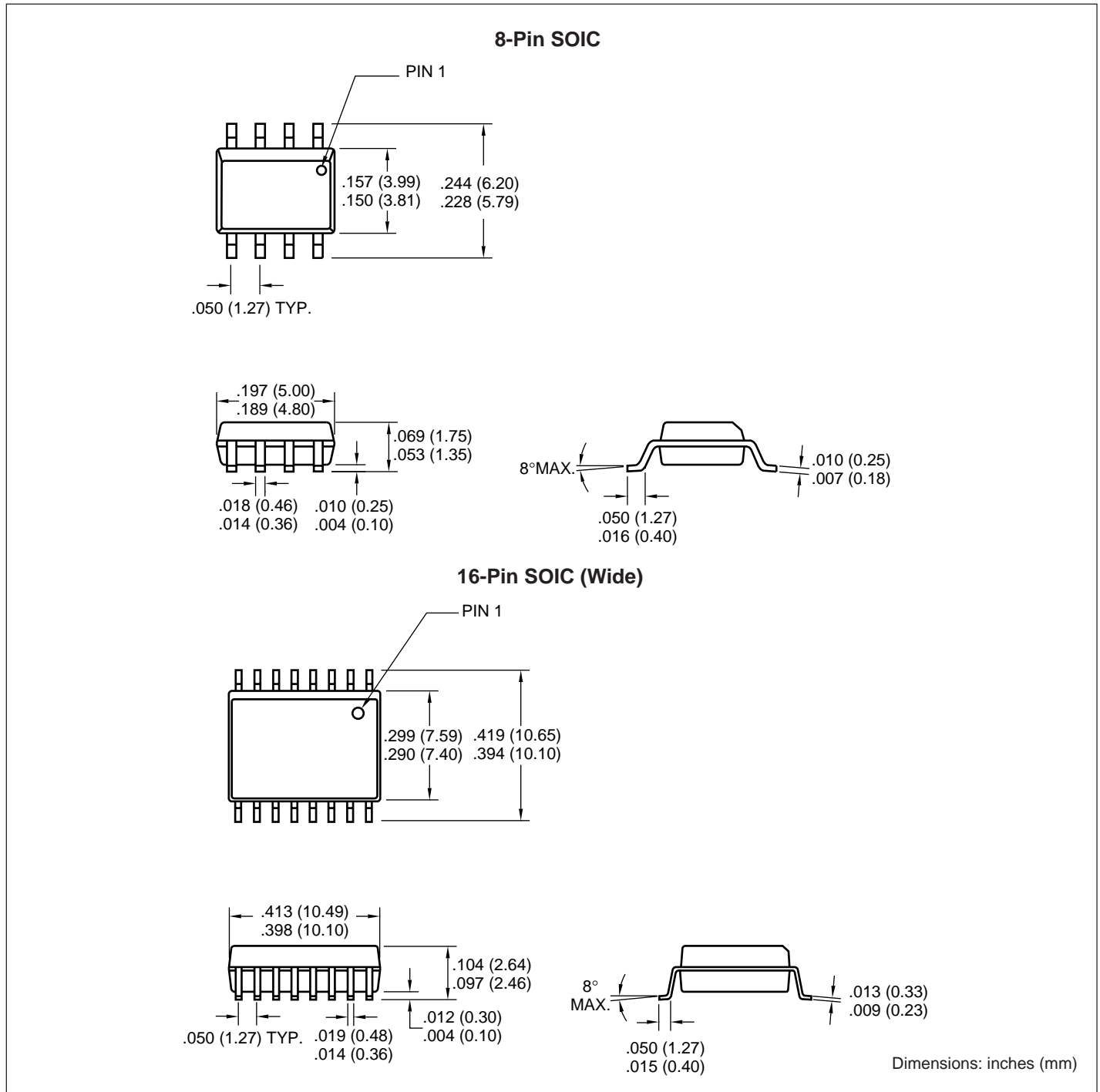

Figure 8. V_{CC} Detect Reset Output Delay (Power-Up)

PACKAGE DIMENSIONS



PACKAGE DIMENSIONS (CONT.)



Sales Offices

TelCom Semiconductor
 1300 Terra Bella Avenue
 P.O. Box 7267
 Mountain View, CA 94039-7267
 TEL: 415-968-9241
 FAX: 415-967-1590
 E-Mail: liter@c2smtp.telcom-semi.com

TelCom Semiconductor
 Austin Product Center
 9101 Burnet Rd. Suite 214
 Austin, TX 78758
 TEL: 512-873-7100
 FAX: 512-873-8236

TelCom Semiconductor H.K. Ltd.
 10 Sam Chuk Street, Ground Floor
 San Po Kong, Kowloon
 Hong Kong
 TEL: 852-2324-0122
 FAX: 852-2354-9957